



Power User #1: Using the Input Library on the AW16G for Electric Guitars, Acoustic Guitars, Basses and Vocals.

By Blake Angelos
Product Specialist, Digital Product Support Group
Yamaha Corporation of America

The Yamaha AW16G is the newest product in Yamaha's family of powerful professional audio workstations. What you get in this product is all of the important features of the AW4416 and AW2816 in a remarkably cost efficient package. **Standard** on the AW16G are

- **A 20 gigabyte internal hard drive and built-in fast CD-RW drive**
- **4 bands of fully parametric EQ for every input**
- **Dynamics processing on every input**
- **2 powerful 32-bit effect processors**
- **A very cool quick loop sampler with over 270 megabytes of drum loops, one shot samples and sound effects available to you directly from the hard drive**
- **Remote control functions for controlling popular external software packages and keyboard workstations like the Yamaha Motif**

...and more! The bottom line? The AW16G delivers on the promise of what you would expect from something that claims to be a *Professional* Audio Workstation. This quick guide is designed to help the electric guitarist, acoustic guitarist, bassist and/or vocalist understand how to use the powerful input effect library on the AW16G. I'll start by first describing how to route an electric guitar through an input channel, set the appropriate levels and then apply input effects to the guitar. Then I'll briefly describe how to do the same thing with an acoustic guitar, bass or vocal input.

- **Input Channel Effects and Electric Guitar:**

First, let's take a look at the back panel of the AW16G:

Fig. 1: Input/output jacks on AW16G

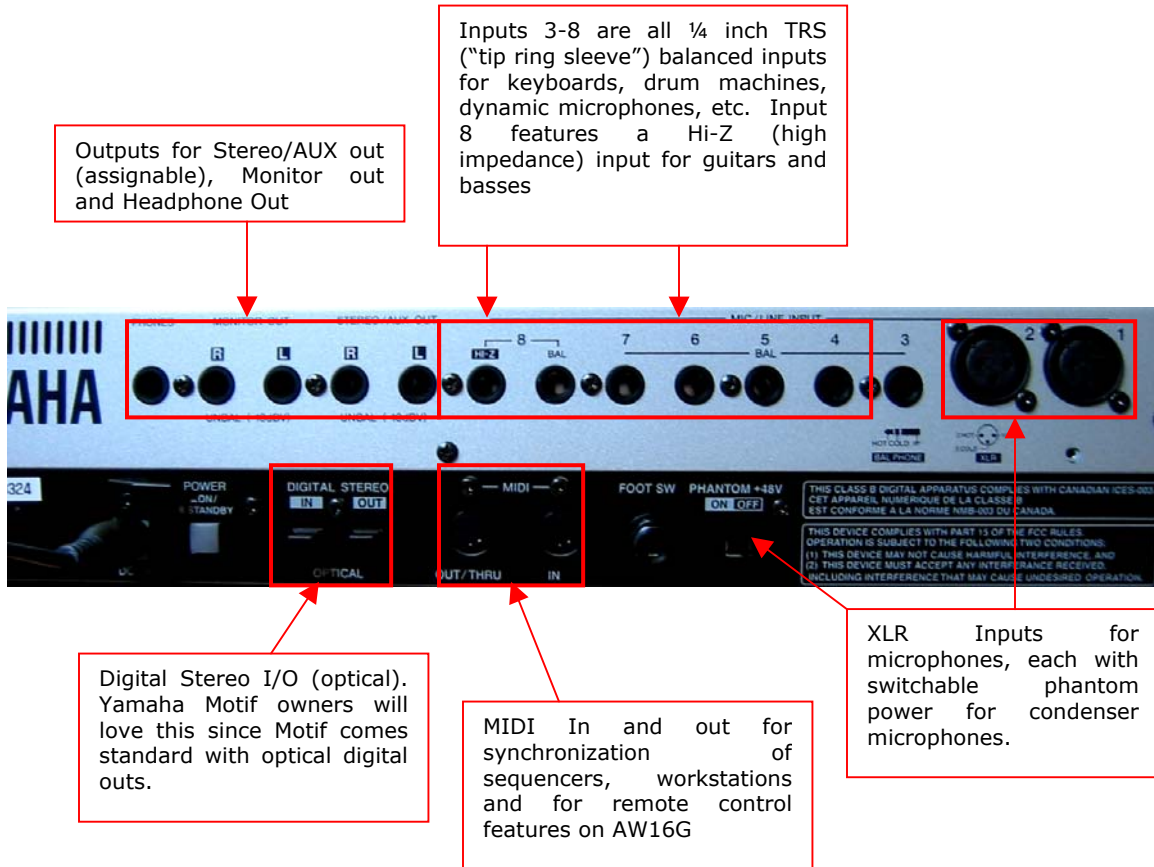

You will need to monitor your output in some way, so you will have to:

- Get a pair of headphones and come out of the PHONES out on the back, or
- Come R-L out of the MONITOR outs into either amp/speaker system or a pair of powered speakers such as the Yamaha MSP5s or MSP3s.

After you have this set up, plug an electric guitar into the Hi-Z input (Channel 8) of the AW16G then press and hold the input channel button on the top of the unit for about a second or so. The input channel screen will pop up, as in Figure 2 below:

Fig. 2: Input Channel Setting

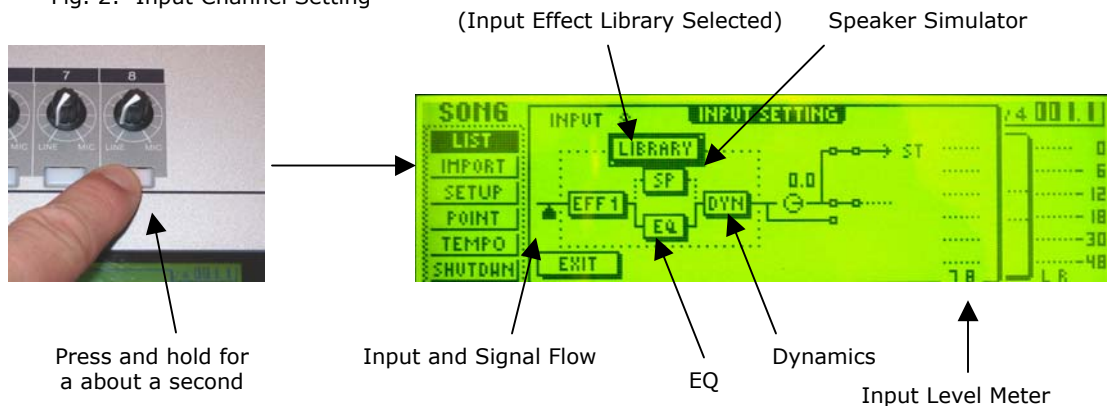

Next you will need to set your levels. Make sure the volume knob on your guitar is up and play nice and strong (a few big chords will do the trick). While you are doing this, make adjustments via the input knob on channel 8 and watch the input level meter as in Figure 3, below:

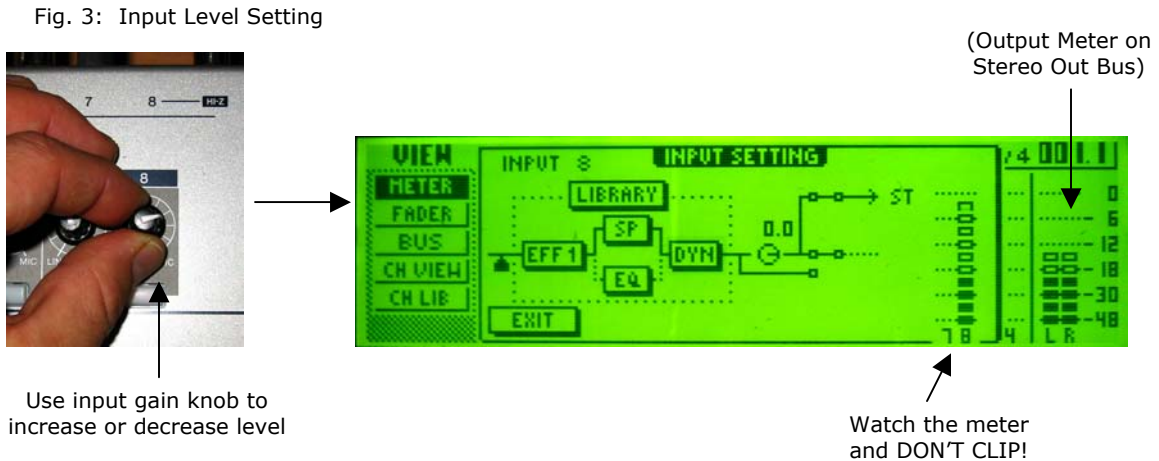

1. Use the \uparrow , \downarrow , \leftarrow , \rightarrow cursor keys located to the right of the unit to move around the LCD display and select "LIBRARY" (as above), then press the [ENTER] button. You will first see this display:

Fig. 4: Release Effect

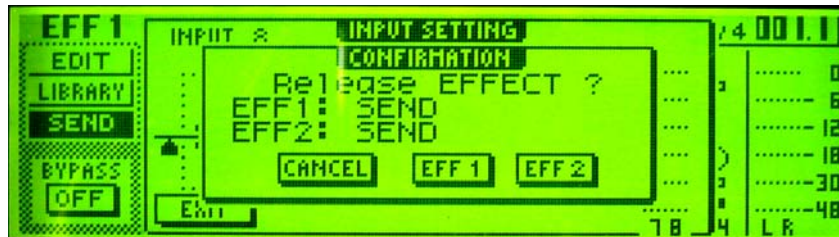

What this is saying is "You are going to use one of the effect processors as an insert to generate the guitar effects. Which one do you want to use and is that okay?" Use the cursor keys to select "EFF 1" and press the [ENTER] button. Realize that when we are done recording the guitar with effects we will be able to place that effect back as a send effect (send for every input and track).

2. You should now see this display:

Fig. 5: Input Library

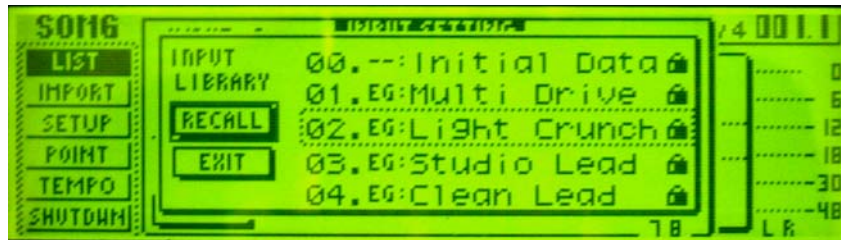

Use the Data Wheel to scroll through the list of effects. Notice that each effect is prefaced by either "EG", "AG", "BA" or "VO". These are effects specifically chosen for Electric Guitar, Acoustic Guitar, Bass and Vocals. Select effect number 02, "EG:Light Crunch", select "RECALL" in the screen and you should now have a nice overdrive effect applied to your guitar. Select "EXIT" to go back to the Input Setting screen¹.

- Now use the cursor keys and select the "SP" setting and press the [ENTER] button. The following screen should now appear:

Fig. 6: Speaker Library

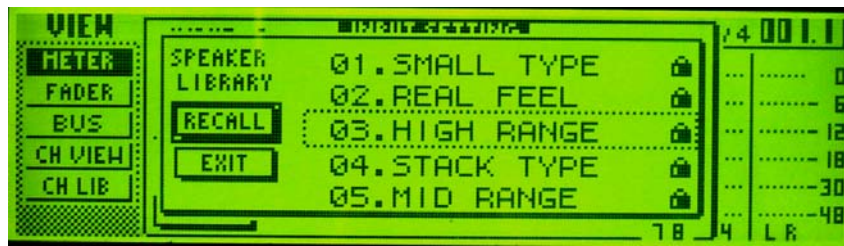

Here you see a selection of 5 different speaker cabinet types. The AW16G manual refers to them like this:

Fig. 7: Speaker Types

Speaker simulation			
01	SMALL TYPE	—	Small cabinet simulation
02	REAL FEEL	—	Creates realism (picking produces grit)
03	HIGH RANGE	—	Cabinet with boosted highs
04	STACK TYPE	—	Large cabinet simulation
05	MID RANGE	—	Simulation of a cabinet with distinctive mid-range

If you are into guitar amps, you get the idea of what styles of cabinets this effect is modeling. Select "05. MID RANGE" then select "RECALL". You have now selected a "cabinet with a distinctive mid-range" as your speaker.

- Lastly, let's apply dynamics processing to our guitar. Use the cursor keys, highlight "DYN" and press the [ENTER] key. You should now see this screen:

¹ For a complete listing of all the effect types and descriptions, look to the back of this document or see page 171 in the manual.

Fig. 7: Speaker Types



Select "016. E. Guitar" and press the [ENTER] key. You now have a dynamics processor (in this case, a compressor) applied to your guitar.

So, in just a few moments we have plugged a guitar into and input, adjusted levels, and ran the input through a "virtual" pre-amp, speaker cabinet and dynamics processor. That is powerful!

- **Acoustic Guitar, Bass and Vocals**

Using input effects on Acoustic Guitar, Bass and Vocals follows basically the same procedure as outlined above for the electric guitar. The primary differences are which input you can plug into and which effects you can use².

Acoustic Guitar with Line Out:

The process is essentially the same as outlined above with electric guitar when when you are using an electro acoustic guitar that has a line output.

1. Plug into Channel 8 Hi-Z input.
2. Hold down channel 8 for a few seconds to access the input library.
3. Adjust your input level as outlined above above.
4. When you select INPUT LIBRARY, you will need to scroll down effects 26-30, all of which are designated by the "AG" abbreviation. Select one of these effects for more standard acoustic guitar processing and press RECALL.
5. Experiment with other effects as desired.

Fig. 8: Acoustic Guitar Input Dynamics Library

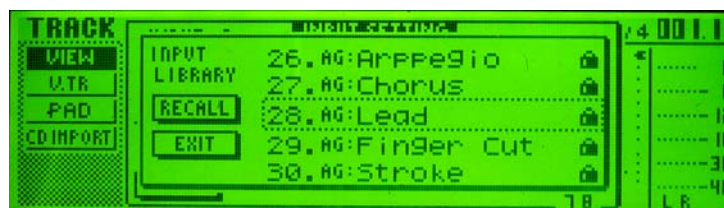

² You can, of course use ANY input effect you want. No one says you can't use one of the overdriven guitar effects on a vocal input: It's YOUR music. There are, nevertheless, some effects that were specifically designed for electric guitar, acoustic guitar, bass and vocals.



Acoustic Guitar with Microphone:

In this scenario you will probably want to use input channels 1 or 2 because you are most likely using an XLR input. If you have a 1/4" balanced cable you will have to use inputs 3-8 (Not the Hi-Z input). These inputs all have microphone preamps that work fine with *dynamic* microphones. If you have a condenser microphone then you will need some phantom power source. Inputs 1 and 2 both have selectable phantom power (see figure one above or look on the back of your unit for the phantom power switch) and will power your condenser microphone.

1. If needed, turn the phantom power switch on the back of the unit to the "on" position and plug your microphone into inputs 1 or 2.
2. Adjust levels as needed.
3. Select one of the input effects and press RECALL.
4. Experiment with other effects as desired.

- **Electric and Acoustic Bass:**

Input Library effects 31-35 were specifically programmed for use with different electric bass playing styles. Plug your bass into channel 8 Hi-Z and adjust input as outlined above, then select input effects 31-35 depending on the style of playing you are looking to sonically enhance. Experiment with other effects as desired.

Fig. 9: Bass Input and Dynamics Library

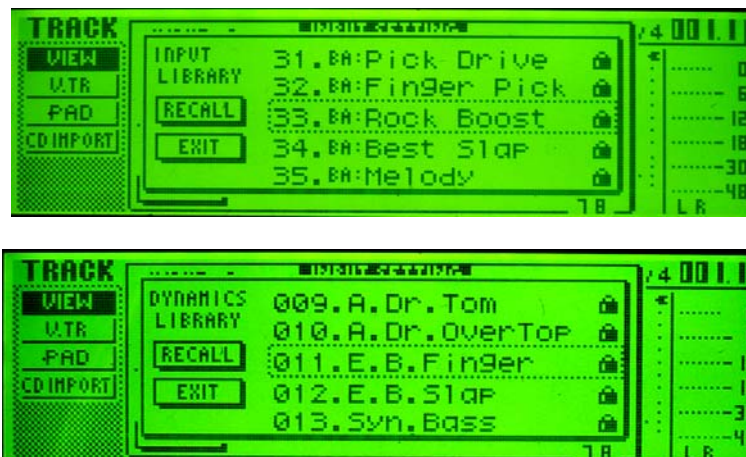

For acoustic bassists, the same idea as above with acoustic guitar considerations can be followed. If you have a bridge pickup, simply plug into channel 8 Hi-Z. If you are using a microphone only plug into channel inputs 1 or 2. There are no acoustic bass effect library parameters per se, but effect "BA:32 Finger Pick" gives a nice meaty, warm sound with a good attack. You can always bypass the input effects as well and

simply use the Effects Library, EQ Library and Dynamics Library and adjust single there as well.

- **Vocal Microphone and other Instruments:**

Input Library effects 36-40 are there for vocal input. Plug your microphone into channel inputs 1 or 2 (making sure the phantom power switch is set to "on" if you are using a condenser microphone), adjust level as desired and select one of the input effects designed for vocal microphone.

Fig. 10: Vocal Input and Dynamics Library



Check out effect VO:40 Robot. This is a special effect that is fun to play with and great for someone looking for a cool effect for different types of dance music.

That's about it! If you want further details look in the AW16G reference manual on pages 39-54 on track recording (page 50-51 is all about the input library).

Fig. 11: Input Library List from AW16G Manual

Input library list

No.	Name	Effect Type	Description
00	Initial Data		Initialize to a default state in which EQ, DYN, and EFFECT are not applied
EG: Electric guitar			
01	Multi Drive	AmpSimulate	Drive sound usable in a wide range of situations from backing to lead
02	Light Crunch	AmpSimulate	Light crunch sound suitable for chords (that are allowed to ring)
03	Studio Lead	Dist->Delay	Lead with delay sound, with an amp-like character
04	Clean Lead	Rev->Sympho	Clean and transparent sound
05	Hard Blues	AmpSimulate	Hard blues sound with rich distortion
06	Melody Drive	Dist->Delay	Long sustaining sound suitable for melodies or ballades
07	Pop Rythm	Mono Delay	Clean backing sound with doubling
08	Heavy Rock	AmpSimulate	Heavy rock sound with all frequency ranges distorted
09	Stack Lead	AmpSimulate	Sound that simulates an old amp stack
10	Funk Cut	Dyna.Phaser	Phase sound that adds an effect to the picking attack
11	Trad Blues	AmpSimulate	Simulation of a traditional blues guitar sound
12	NeoRockabilly	Dist->Delay	Rockabilly sound using a short delay, warped by adding distortion
13	Air Clean	Delay+Rev	Clean sound with a sense of air
14	City Lead	Mod.Delay	Combination sound with lightly applied modulation and delay
15	Pop Chorus	Chorus	Chorus sound suitable for a wide range of uses, from chording to arpeggios
16	Fuzzy Drive	AmpSimulate	A useful and original fuzz sound
17	Jazzy Night	Reverb Room	Comp sound that lets you express nuances by your picking dynamics
18	Retro Phase	Phaser	Simulation of a classic compact phaser
19	Mistic Chord	Dual Pitch	SFX sound that produces a mystical effect from chords or harmonics
20	Drive Amp	AmpSimulate	Natural-sounding overdrive that simulates overdriving a combo amp
21	Smooth Lead	AmpSimulate	Smooth distortion lead with a smooth playing feel
22	Crunch Box	AmpSimulate	Crunch sound with a nice amount of distortion, usable for anything from backing to lead
23	Double Drive	Dist->Delay	Heavy distortion with doubling
24	Comp Driver	AmpSimulate	Overdrive with compressor to bring out the nuances of your picking
25	Rotary	Rotary	The familiar rotary speaker sound, optimized for guitar
AG: Acoustic guitar			
26	Arpeggio	Rev+Sympho	Graceful arpeggio sound with good definition
27	Chorus	Chorus	Deep chorus sound usable in any situation
28	Lead	Mod.Delay	Light modulation sound, suitable for lead guitar
29	Finger Cut	ReverbRoom	Suitable for finger strumming or walking-bass phrases
30	Stroke	Symphonic	Symphonic sound effective on single-note melodic playing
BA: Bass			
31	Pick Drive	AmpSimulate	A sound ideal for root-note picking
32	Finger Pick	AmpSimulate	Sound suitable for finger-picking, with emphasis on response
33	Rock Boost	AmpSimulate	Heavy and solid distortion sound
34	Best Slap	AmpSimulate	Slap bass sound for everyone (reminiscent of when slap became fashionable)
35	Melody	Rev->Chorus	Sweet-toned sound for lead melodies
VO: Vocal			
36	Pop Vocal	ReverbPlate	Clear and transparent effect for vocal, that cuts the low range
37	Rock Vocal	MonoDelay	Effect for rock vocal that uses doubling to create depth
38	Delay Vocal	MonoDelay	Vocal effect that uses a basic delay
39	Ballad Vocal	Symphonic	Vocal effect with symphonic, effective on ballades etc.
40	ROBOT	RingMod	SFX sound for vocal and speech, also usable as a sound-effect